

## Installation Manual

# ***OPW Fluid Transfer Group Europe B.V.***



## ***Rack Monitor 8800E / 8801E***

Version B.1  
Date 24 August 2016

**OPW**<sup>®</sup> Fluid Transfer Group  
Europe B.V. A DOVER COMPANY

**CIVAcon**<sup>™</sup>

## Disclaimer

In this document an installation manual is presented of the **OPW** Rack Monitor 8800E/8801E. It is important that the end user (in many cases the operator) of the **OPW** Rack Monitor 8800E/8801E has an adult age, is skilled, reads and understands this manual (and therefore has knowledge of the English language), otherwise it is not recommended to use the **OPW** Rack Monitor 8800E/8801E.

**OPW Fluid Transfer Group Europe BV** guarantees that this product is adequate for the stated use in chapter 1 and is in accordance with the Directive(s) stated in the declaration of conformity in this manual.

**OPW Fluid Transfer Group Europe BV** cannot be held responsible for incorrect use of the RACK MONITOR 8800E/8801E. The Rack Monitor 8800E/8801E is for the use of monitoring of loading of tank trucks with the application and parameters stated in chapter 1 of this manual.

***In case this OPW Rack Monitor 8800E/8801E is used in another location then mentioned in the initial quotation or is abused, all guarantees will be declined.***

This installation manual is a part of the supplied product and must at all times accompany the Rack Monitor 8800E/8801E, when it is relocated or sold to a third party. All pages of this manual should be present, in accordance to the table of contents. If not, please contact the **OPW Fluid Transfer Group Europe BV**.

© COPYRIGHT 2007. The design, drawings and documentation are the exclusive property of **OPW Fluid Transfer Group Europe BV**. It is submitted on the condition that the designs contained therein are held confidential and is subject to return on demand.

Apart from exceptions provided by the law, nothing from this publication may be duplicated and/or published by means of photography, microfilm, storage in computer files or otherwise, which also applies to full or partial processing, without the written consent of **OPW Fluid Transfer Group Europe BV**.

Although the utmost care has been taken with this publication, errors and omissions cannot be entirely excluded. The **OPW Fluid Transfer Group Europe BV** therefore accepts no liability, not even for direct or indirect damage, occurring due to or in relation with the application of publications issued by **OPW Fluid Transfer Group Europe BV**.

This is an **OPW Fluid Transfer Group Europe BV** product, for technical assistance, information and/or complaints contact:

## OPW Fluid Transfer Group Europe BV

Visiting adress:

Roggestraat 38  
2153 GC Nieuw Vennepe

Postal adress:

P.O.Box 32  
2150 AA Nieuw Vennepe

T: +31 (0)252 660 300

F: +31 (0)252 660 204

E: [sales@opw-ftg.nl](mailto:sales@opw-ftg.nl)

W: <http://www.opw-ftg.nl>

Mr. Harry Gilde  
**Managing Director**

## ***Warranty***

All parts and products are thoroughly inspected and tested from the time raw material is received at our plant, until the product is completed. We guarantee that all products are free from defects in materials and workmanship for a period of one year from the date of shipment. Any product that may prove defective within said one year period will, at our option, be promptly repaired, or replaced, or credit given for future orders. This warranty shall not apply to any product which has been altered in anyway, which has been repaired by any party other than an authorized service representative, or when such a failure is due to misuse or conditions of use. We shall have no liability for labour costs, freight costs, or any other cost or charges in excess of the amount of invoice for the products.

THIS WARRANTY IS IN LIEU OF ALL OTHER WARRANTIES, EXPRESS OR IMPLIED, AND SPECIFICALLY THE WARRANTIES OF MERCHANTABILITY AND FITNESS FOR A PARTICULAR PURPOSE.

## ***Approvals***

The 8800E/8801E CIVACON Loading Rack Monitor is suitable for Equipment group II, category 2(1)

hazardous locations with intrinsically safe outputs, and housed in an Explosion Proof Enclosure. All monitors are ATEX approved. Please consult the factory for the availability of special models.

## ***Technical assistance in the U.S.A.***

If at any time during the installation a question arises that is not covered in this Installation Instruction, or with any other applicable documents referenced, feel free to call the CIVACON ELECTRONICS TECHNICAL ASSISTANCE LINE :

**In the U.S.A., Call 1-800-5 CIVACON . (800-524-8226)**

For the CUSTOMER SERVICE DEPARTMENT :

**In the U.S.A., Call 1-888-526-5657**

In other countries, call your local agent.

4304 MATTOX RD. \* KANSAS CITY, MO 64150  
PH: (816) 741-6600 \* FAX: (816) 741-1061  
(888) 526-5657 (888) 634-1433

## Important.

Entity parameters for pin 11 on all rack 8800E rack monitors with a serial number starting with a “1” has been changed.

Terminals						
Entity Parameters	2 Wire CN2 / pin1~8	5 Wire CN2 / pin 4,5,6,8	Grounding CN2 / pin9	Data CN2 /pin11	Emergency Sw CN5	Internal CN7
U <sub>o</sub>	12,6 V	12,6 V	12,6 V	12,6 V	12,6 V	12,6 V
I <sub>o</sub>	200mA	800mA	56mA	121mA	28mA	45mA
P <sub>o</sub>	630mW	2,52 W	178mW	380mW	89mW	1,41W
C <sub>o</sub>	3,7 μF	3,7 μF	3,7 μF	3,7 μF	3,7 μF	3,7 μF
L <sub>o</sub>	2mH	110 μH	22,5mH	4.5mH	90mH	32,5mH

## Table of Contents

Installation Manual .....	1
Disclaimer .....	2
Warranty.....	3
Approvals .....	3
Technical assistance in the U.S.A. ....	3
Table of Contents .....	4
<b>1 Specifications.....</b>	<b>6</b>
1.1 Specifications inside Enclosure .....	6
1.1.1 Specifications Printed Circuit Board (PCB) .....	6
1.2 Specifications external environment .....	7
1.2.1 Cable Glands Specifications.....	7
1.3 General Specifications .....	7
1.3.1 Bolts .....	8
1.3.2 Package Dimensions .....	8
1.3.3 Storage of the Rack Monitor 8800E/8801E .....	8
1.4 Nameplate .....	8
1.5 Compliance .....	9
<b>2 Initial installation.....</b>	<b>10</b>
2.1 Safety precautions .....	10
2.2 Installation Preparations.....	10
2.3 Installation Rack Monitor 8800E/8801E.....	10

<b>Mounting Points .....</b>	<b>12</b>
2.4 Electrical wiring / installation .....	14
Sensor.....	14
2.4.1 Mains wiring .....	17
2.4.2 Relay outputs .....	18
2.4.3 Data communication .....	20
<b>3 System configuration .....</b>	<b>22</b>
<b>4 Maintenance .....</b>	<b>24</b>
4.1 Check Points .....	24
<b>5 Operational Use .....</b>	<b>24</b>
<b>6 Dismantling Rack Monitor .....</b>	<b>25</b>
<b>7 Trouble shooting.....</b>	<b>26</b>
<b>8 Procedure in case of an Error or Emergencies .....</b>	<b>26</b>
<b>Sensor cable specifications:.....</b>	<b>27</b>
<b>Annex A - Available detail wiring drawings of the Rack Monitor 8800E/8801E and associated parts ..</b>	<b>28</b>
<b>Annex B - Modification Mounting Holes .....</b>	<b>28</b>
<b>Annex C - Recommended Spare Parts.....</b>	<b>28</b>
<b>Annex D - Official documents .....</b>	<b>Fout! Bladwijzer niet gedefinieerd.</b>
<b>Rack Monitor Test equipment. ....</b>	<b>29</b>

# 1 Specifications

The Rack Monitor 8800E/8801E is a loading rack monitoring system detects and communicates an overflow condition to the loading rack control automation equipment by means of a normally open relay contact. In addition this non-permissive condition as well as diagnostic information is displayed. A typical system contains loading rack control monitor (88xxE Rack Monitor) and a API 10 wire screened coiled cable with a black 10 pins 4 J-slot plug (Model 7400E).

Thermistor and optic signal inputs allow compatibility with the NEN-EN13922 and two other API standard signaling conventions commonly used in the industry. Either of these signals comes from the truck/trailer mounted on-board control monitor or sensors. The 88xxE rack monitor supersedes the 84xx and 85xx type rack monitors and are suitable for hazardous locations with intrinsically safe outputs, and are housed in a IP 65, Explosion Proof “d” Enclosure.

There are two versions available. The Rack Monitor 8800E is a complete version with display. The Rack Monitor 8801E is a version without a display. The installation of both versions is the same.

## 1.1 Specifications inside Enclosure

Free Volume : <3L empty, <2.2L with Main PCB and Display PCB  
Internal Pressure : 80 kPa (0.8 bar) to 110 kPa (1.1 bar) (atmospheric pressure)

### 1.1.1 Specifications Printed Circuit Board (PCB)

#### Mains:

Nominal min. input voltage : 110 Vac.  
Nominal max. input voltage : 230 Vac.  
Frequency : 50 / 60 Hz

The nominal power consumption depends on ambient temperature.  
Above 0°C (32°F) no internal heating is needed

Nominal power consumption : 20VA.

Below 0°C (32°F) a certain amount of power is used to keep the liquid display within operating temperature.

Nominal power consumption : 30VA.

Nominal input current : at 110Vac -> 0.4A rms.  
: at 230Vac -> 0.2A rms.

Mains current limitation  
internal fuses : 2AT

#### Relay contacts:

Input voltage : 250V ac/dc max.  
Relay contacts current limitation:  
Internal fuses : 5AT

- All cables will be guided into the Rack Monitor by use of Cable Glands (see Annex A of IEC 60079-0 and Annex C of IEC 60079-1)

## 1.2 Specifications external environment

Temperature Range (T <sub>a</sub> )	: -45°C (-42.8°F) to +70°C
Max. surface temperature (T <sub>4</sub> )	: ≤135°C (21.1°F)
Relative humidity	: 50 ± 5%
IP Class closed	: IP65 acc. to IEC 60529
Resistant to	: UV Light (within Sun light) : Corrosion : Ingress of Gasoline vapours and liquids : (Diesel) Exhaust fumes : Rain Water : All other weather conditions : Explosive Mixtures
External Pressure	: 80 kPa (0.8 bar) to 110 kPa (1.1 bar) (atmospheric pressure)
Air	: normal oxygen content, typically 21% v/v

### 1.2.1 Cable Glands Specifications

Pitch (P)	: $0.7 \geq P \leq 2$ mm
Thread form and quality of fit	: Medium or fine tolerance quality acc. To ISO 965-1 and ISO 965-3
Threads engaged	: ≥ 5
Depth of engagement	: ≥ 8 mm
Execution (ATEX)	: M20
Safety class	: Explosion proof Ex d

## 1.3 General Specifications

Outline size 8800E/8801E	: width = 310 mm : height = 280 mm : thickness = 80 mm
Material	: Aluminum with <7.5% Mg (acc. to IEC 60079-0 Group II, zone 1) : AL 6061
Surface Resistance	: ≤1 GΩ (at 23±2°C and relative humidity stated) (between parts)
Min. X sect. earth con. (S)	: at least 4 mm <sup>2</sup>
Earth continuity torque	: 10 Nm (±10%)
View angle display	: ~25°
Visibility display	: ~0.5 m
View angle LED's	: 120°
Visibility LED's	: 20 m (no direct sunlight)
Seals	: NBR

- The gasket(s) shall be attached or secured to one of the mating faces to prevent loss, damage or incorrect assembly. The gasket material shall not itself adhere to the other joint face and has to be slightly greased.

### 1.3.1 Bolts

Yield Stress Limit	: 450 N/mm <sup>2</sup>
Tensile Stress Limit	: 700 N/mm <sup>2</sup>
Thread engagement (h)	: > D <sub>bolt</sub>

### 1.3.2 Package Dimensions

Package outside dimensions 8800E/8801E (HxWxD)	:45x40x50	cm
Package weight 8800E/8801E	: 12 Kg	(26 lb)
Package outside dimensions 8800E/8801E with cable-plug assembly	:45x40x50	cm
Package max weight with cable-plug assembly	: 25 Kg	(55 lb)

Keep the Rack Monitor 8800E/8801E into the initial box and store it into a dry warehouse. Make sure (before installation or storage) to check if the package and the Rack Monitor 8800E/8801E is free from damages.

### 1.3.3 Storage of the Rack Monitor 8800E/8801E

Storage Temperature (T<sub>s</sub>) : -20°C (-4°F) to +70°C

The storage and transport ambient temperature of the 8800E/8801E may never exceed the above mentioned temperature range to prevent damage to the liquid crystal display.

Read installation chapter for recommended precautions when the 8800E/8801E is used in the maximum ambient operating temperature range.

The Liquid crystal display must be shielded from direct sunlight.

## 1.4 Nameplate

The nameplate of the Rack Monitor 8800E/8801E is affixed to the outside of the bottom part of the Enclosure. The material is stainless steel and will be attached to the Enclosure by means of 4 stainless steel drive screws (see Figure 1). The font used on the nameplate is Arial in sizes 2 to 3.5 points high, depending on the information containing. The nameplate contains at least the supplier, brand, type, serial number, year of manufacturing, protection type, certificate number, temperature range and product category.

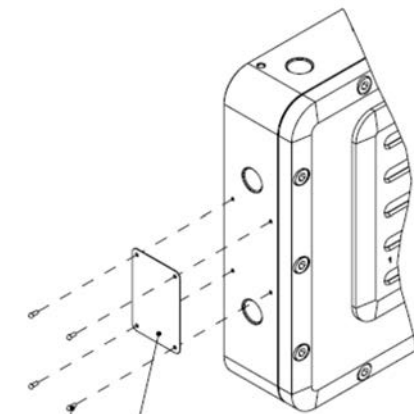

**Figure 1**



## 1.5 Compliance

See inserted Declaration of conformity H71794 for the latest standards and directives.  
Please contact OPW when this document is missing

To get the Rack Monitor enclosure with a CE marking, the following directives are applicable

The Rack Monitor 8800E/8801E is designed with the use of the following standards.

### **Used Standards:**

IEC/EN 60079-0	:	<i>Electrical apparatus for explosive gas atmospheres – Part 0</i>	:	<i>General requirements</i>
IEC/EN 60079-11	:	<i>Electrical apparatus for explosive gas atmospheres – Part 11</i>	:	<i>Intrinsic safety "i"</i>
IEC/EN 60079-1	:	<i>Electrical apparatus for explosive gas atmospheres – Part 1</i>	:	<i>Flameproof enclosures "d"</i>
IEC/EN 60079-26	:	<i>Electrical apparatus for explosive gas atmospheres – Part 26</i>	:	<i>eq. prt. Level (EPL) Ga</i>
IEC 60529	:	<i>Degrees of protection provided by enclosures (IP Code)</i>		
EN 13922	:	<i>Tanks for transport of dangerous goods - Service equipment for tanks – Overfill prevention systems for liquid fuels</i>		

### **With regard to the Electromagnetic Compatibility the following standards are applied:**

EN 61000-6-2	:	<i>Generic standards, Immunity for industrial environments</i>
IEC/EN 61000-4-2	:	<i>Electrostatic discharge immunity test (ESD,)</i>
IEC/EN 61000-4-3	:	<i>Radiated radio-frequency electromagnetic field immunity test,</i>
IEC/EN 61000-4-4	:	<i>Electrical Fast Transient/burst immunity test (EFT),</i>
IEC/EN 61000-4-5	:	<i>Surge Immunity test,</i>
IEC/EN 61000-4-6	:	<i>Immunity to conducted disturbances, inducted by radio-frequency fields</i>
IEC/EN 61000-4-11	:	<i>Voltage dips, shorts interruptions and voltage variations,</i>
EN 61000-6-4	:	<i>Generic standards, Emission for industrial environments</i>
EN 55011	:	<i>Conducted emission Radiated emission</i>
EN 61000-3-2	:	<i>Harmonics</i>
EN 61000-3-3	:	<i>Flicker</i>

## Initial installation

**Attention:** Installation must be performed by authorized and trained personnel only.

### 1.6 Safety precautions

**Warning:** Read & Understand this instruction before starting installation.

- Equipment to be used for its designated purpose only.
- Local regulations for installation have to be followed at any time.
- Product flow may result in static electricity, earthing of the equipment is required.
- OPW instructions must be followed for installation of any OPW Product at any time.
- **Make sure to use adequate personal protection at all time during the operation,**

**Caution:** **Switch OFF mains power before making any connections**

### 1.7 Installation Preparations

For safe and efficient transportation, Rack Monitor 8800E/8801E's is packed in a box. Each shipment can contain one or more boxes with fastening materials for assembly of the Rack Monitor 8800E/8801E. Also optional accessories are packed in boxes.

When on arrival one decides to store the Rack Monitor 8800E/8801E for later use, keep the Rack Monitor 8800E/8801E into the initial box and store it into a dry warehouse (for details see chapter 1.3.3). Make sure (before installation or storage) to check if the Rack Monitor 8800E/8801E is free from damages.

All Rack Monitor 8800E/8801E's will have an unique identification by means of an unique serial number.

Bolts, nuts and washers for mounting of the Rack Monitor 8800E/8801E are included in the scope of supply. Following requirements apply for these materials:

- Bolt material minimum Stainless Steel class A2-70
- Torque setting as per bolt class.

No special tools or equipment for installation of the Rack Monitor 8800E/8801E are required. Make use of metric Allen Keys and metric wrenches to secure the nuts from rotating.

### 1.8 Installation Rack Monitor 8800E/8801E

Steps to mount the Rack Monitor 8800E/8801E:

- Remove the Rack Monitor 8800E/8801E from the box and make sure it is free from damages,
- Check if the Rack Monitor 8800E/8801E corresponds to the drawing in Figure 2.

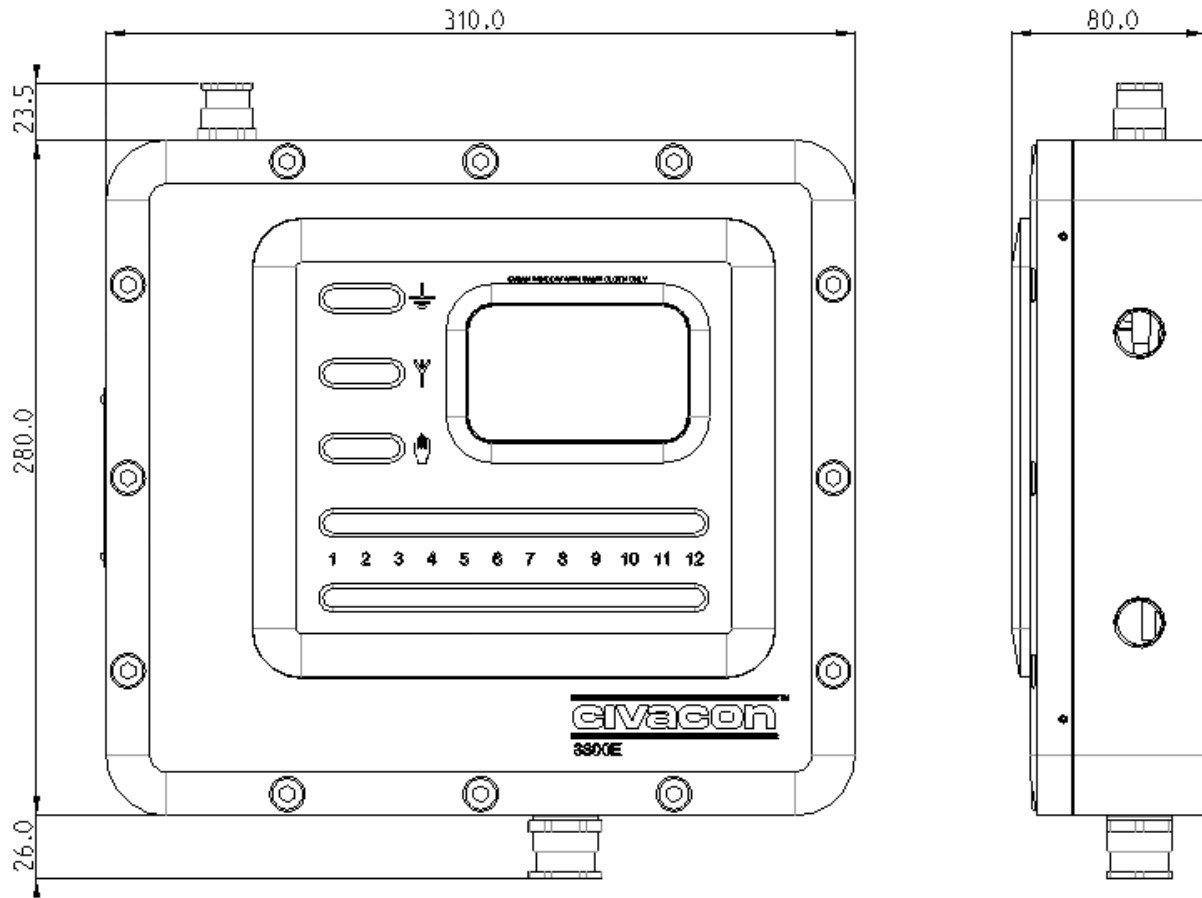

**Figure 2**

- Remove the 12 bolts mounted into the door,
- Open the door as far as 180°,

**Warning:** Make sure always to open the door by 180°, because there is a risk that the hinges could be damaged when not opened completely (see Figure 3).

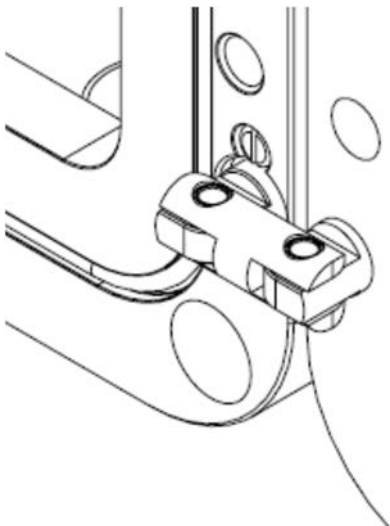

**Figure 3**

- Prepare the designated position for installation,
  - Make sure that the drilled holes are at least 8,4 mm or M8 threaded (when you don't want to use the supplied nuts) and that they correspond to the holes of the enclosure.
  - Position the Rack Monitor 8800E/8801E in front of the drilled holes (see **Fout! Verwijzingsbron niet gevonden.**),
  - Attach the Hexagon slotted bolts M8x65 and fixate them with the supplied M8 nuts (see **Fout! Verwijzingsbron niet gevonden.**),
- Or
- Tap M10 screw thread in the back of the enclosure, to mount the Rack Monitor 8800E/8801E from the rear (see Annex B - Modification Mounting Holes for instructions) using M10 bolts,

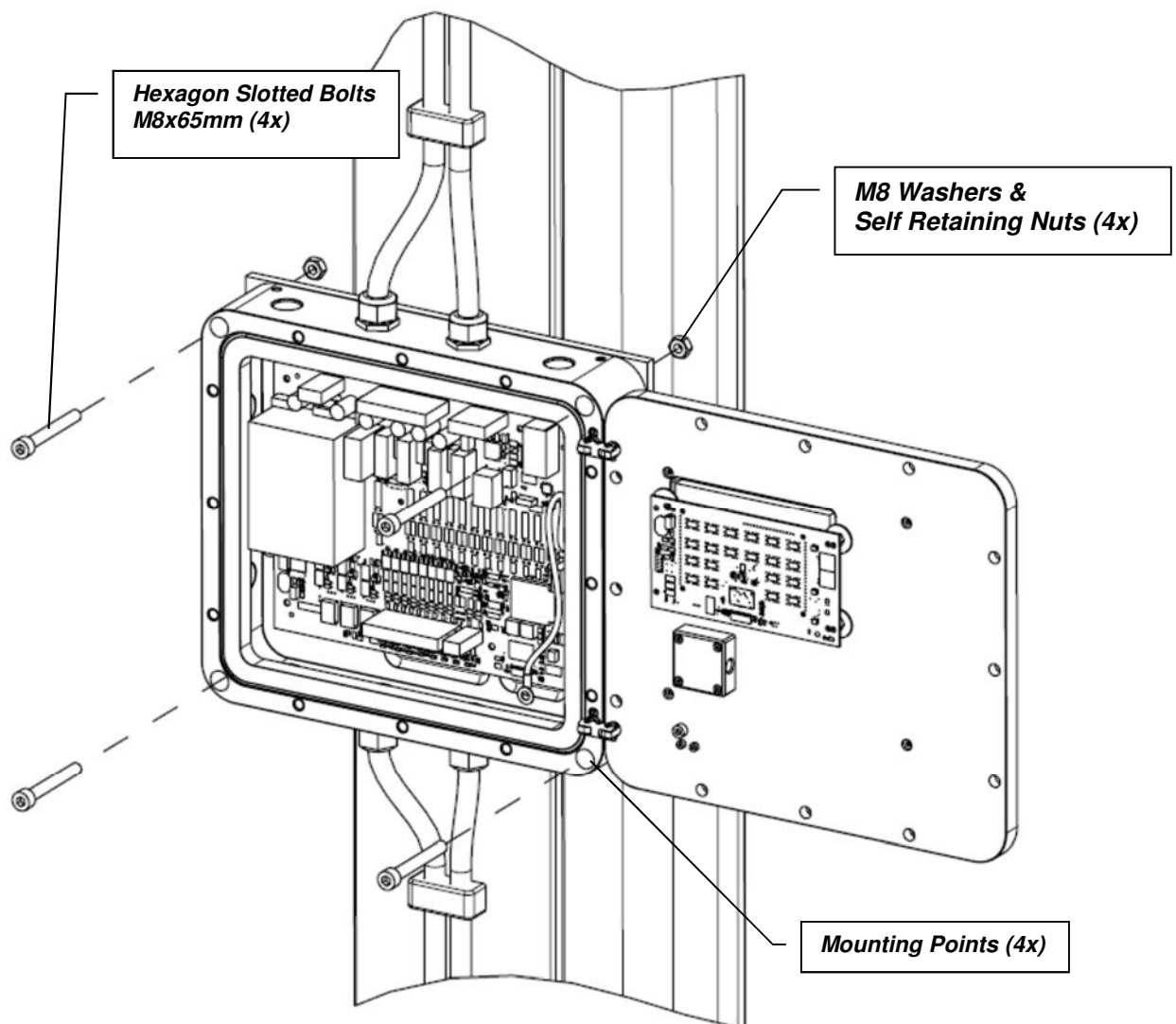

Figure 4

## Mounting Points

- Tighten the bolts and the nuts with a minimum of 14.5 Nm and a maximum torque of 27.6 Nm,
- Select a suitable cable gland that meets the cable outer diameter.
- Secure the (Ex "d" M20x1,5mm Certified) cable glands into the desired location.

- Determine the conductor length required to connect to the designated terminal block and prepare the cable accordingly, removing part of the outer sheath where required to reveal the insulated conductors. (wires should be cut to length with no excessive wire coiled inside the enclosure).
- Strip the insulated wires to the desired length (OPW recommends the use of bootlaces or crimping pins to connect multi-stranded wires. This provides a secure connection to terminal blocks and captive terminals and stop wire strands short circuiting to adjacent connectors).
- Ensure that the seal is in a relaxed state by unscrewing the seal nut until there is no compression on the seal.
- Pass selected cable through the gland to desired position, then tighten seal nut by hand until heavy resistance is felt, then rotate one full turn with the appropriate spanner
- Start connecting the wiring according to the following steps,

Note : Use one of the two provided ground bolts ( see Figure 5 ). to ensure a proper and reliable **grounding** (electrical bonding ) .

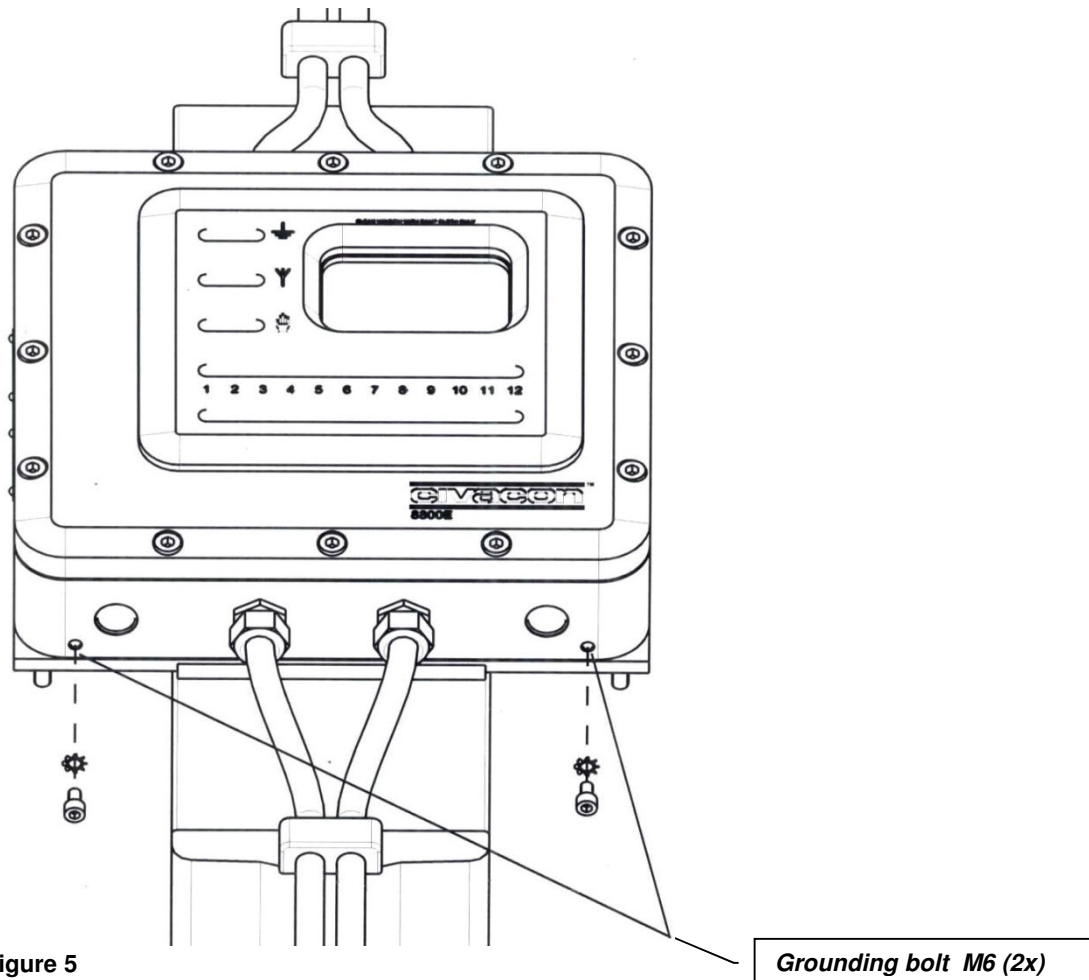

Note : The connection of cables and conduits to the Rack Monitor should be made in accordance with requirements of the relevant type of protection. Cables and cable glands must be in accordance with the type of protection. Unused openings must be closed with blanking elements suitable for the relevant type of protection. The blanking elements must be certified for the type of protection and can be removed only with the aid of tools. The product connections must guarantee the degree of protection. Instruction Manual of the certified cable glands and blanking elements must be observed.

Note : Do not drill any additional (conduit) hole in the rack monitor enclosure. This will violate the enclosure's approvals and voids the warranty.

## 1.9 Electrical wiring / installation

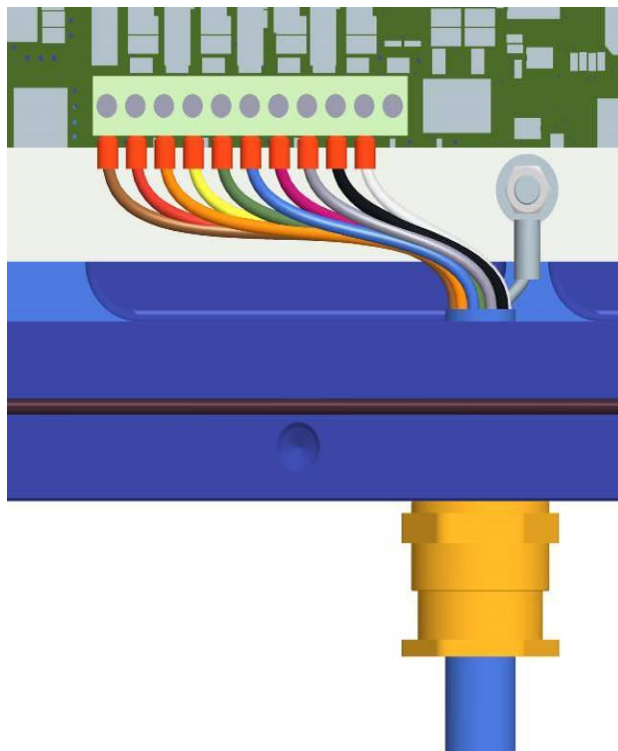

### Sensor

For connecting the monitor to the sensors mounted on a tank-truck a plug and cable set is being used. If the monitor is set to EN13922 specifications a 10 wire cable with a Black plug **MUST** be used. However, if needed and used outside the European union a cable and Blue 3-J-plug can be provided (Civacon Model 7100). Although a plug and cable set can be directly connected to the monitor, it is recommended to do this through a junction box to prevent or limit the damage caused by tank-trucks driving away with the plug still attached to the socket.

The connections of the cable to the plug according EN13922 are shown in Figure 6 and Figure 7. In Table 1 is shown the alternative colour-code and functional descriptions of all 10 wires.

Only Ex certified sensors within entity parameters mentioned in Table 3 may be connected to the 8800E and 8801E. OPW also recommends to use only EN13922 sensors to ensure compatibility.

**Figure 6**

Note : read cable specifications mentioned under entity parameters

It is recommended to leave this pin 11 unconnected to avoid disturbance on the other lines if not used. See truck data communications below for details.

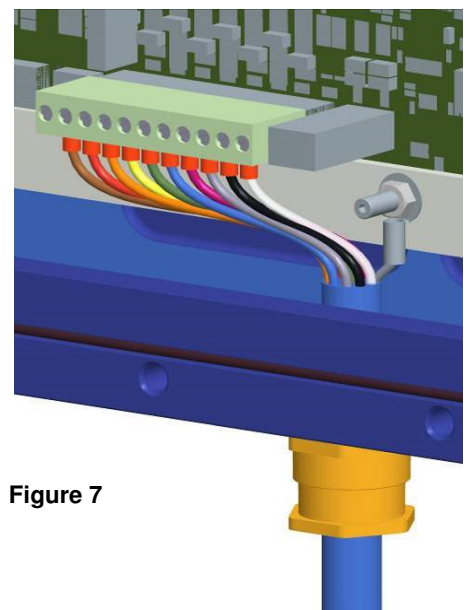

**Figure 7**

### Five-wire pin usage

EN13922 Colour	Current Colour	US Colour	US Colour
<b>7400E</b>	7110	7300	7100
<b>Black</b>	Blue	Green	Blue
<b>4J Plug</b>	3J Plug	4J Plug	3J Plug

Plug & terminal Pin No.	10 Pins	6 Pins	10 Pins	6 Pins	
1	<b>Brown</b>		<b>Brown</b>		nc
2	<b>Red</b>		<b>Green</b>		nc
3	<b>Orange</b>		<b>Red</b>		nc
4	<b>Yellow</b>	<b>Yellow</b>	<b>Yellow</b>	<b>Yellow</b>	Pulse to sensors
5	<b>Green</b>	<b>Green</b>	<b>Black</b>	<b>Green</b>	Diagnostic
6	<b>Blue</b>	<b>Blue</b>	<b>Blue</b>	<b>Orange</b>	Pulse Return
7	<b>Violet</b>		<b>Violet</b>		nc
8	<b>Grey</b>	<b>Grey</b>	<b>Orange</b>	<b>Red</b>	Power
9	<b>Black</b>	<b>Black</b>	<b>Grey</b>	<b>White</b>	Ground verification
10	<b>White</b>	<b>White</b>	<b>White</b>	<b>Black</b>	Ground return

### Two-wire pin usage

EN13922 Colour	US Colour
<b>7400E</b>	7300
<b>Black</b>	Green
<b>4J Plug</b>	4J Plug

Plug & terminal Pin No.	10 Pins	10 Pins	
1	<b>Brown</b>	<b>Brown</b>	Input compartment 1
2	<b>Red</b>	<b>Green</b>	Input compartment 2
3	<b>Orange</b>	<b>Red</b>	Input compartment 3
4	<b>Yellow</b>	<b>Yellow</b>	Input compartment 4
5	<b>Green</b>	Black	Input compartment 5
6	<b>Blue</b>	<b>Blue</b>	Input compartment 6
7	<b>Violet</b>	<b>Violet</b>	Input compartment 7
8	<b>Grey</b>	<b>Orange</b>	Input compartment 8
9	<b>Black</b>	<b>Grey</b>	Ground verification
10	<b>White</b>	<b>White</b>	Ground return

**Table 1**

*Note:*

*In all above cases plug-pin number must be connected to the same terminal pin number. e.g. plug-pin 1 must be connected to terminal pin 1 etc.*

## Emergency-switch

An emergency switch or dead man switch can be connected at the terminal shown in Figure 8. On the right side of the 10+1 tank truck sensors terminal strip a 2 pin terminal strip is placed.

This is an intrinsically safe normally closed input (latched or un-latched).

As soon as the switched is opened (or broken wire) the Rack monitor 8800E/8801E will switch to NON permissive. If this input is NOT used a connection MUST be made between the two pins. See **Fout! Verwijzingsbron niet gevonden..**

An overview of all Intrinsically safe connections is shown below in **Fout! Verwijzingsbron niet gevonden..**

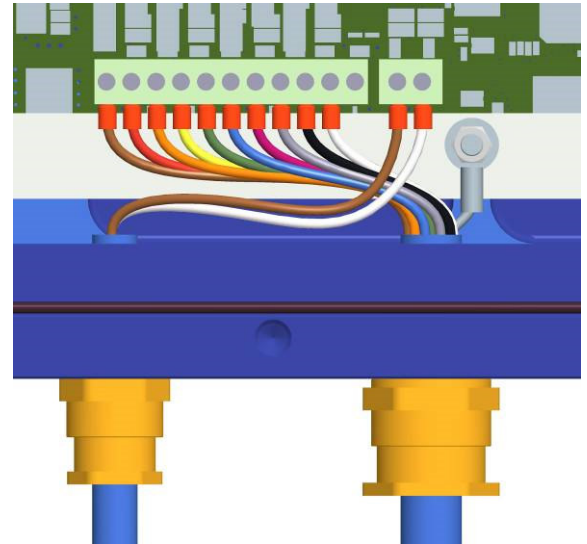

Figure 8

## Truck data communication.

All rack monitors with serial number starting with a "1" can be used to read a Vehicle Id on the truck. A connection must be made between pin 11 and 9 on terminal (See Figure 8) Dip switch "0" (outmost right). must be set to activate the software.

Entity parameters of both channels has to be combined. See operating manual for used RS485 Data protocol.

OPW / Civacon advise to use ViD 1951  
See H72109 for details



picture 1



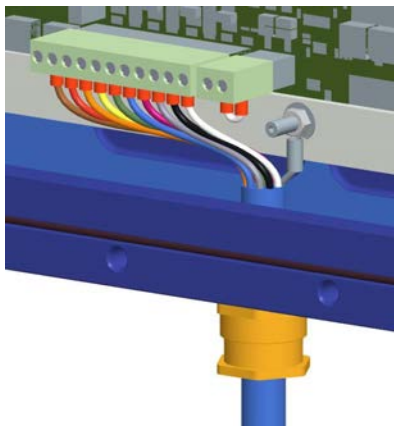

Figure 10

To bypass the emergency switch connect pin 1 to pin 2 by means of a short piece of wire. The color is not important and can be chosen randomly. See **Fout! Verwijzingsbron niet gevonden..**

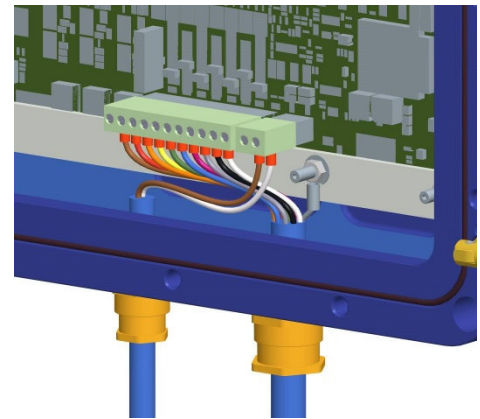

Figure 9

### Mains wiring

**CAUTION:** Switch OFF mains power before making any connection.

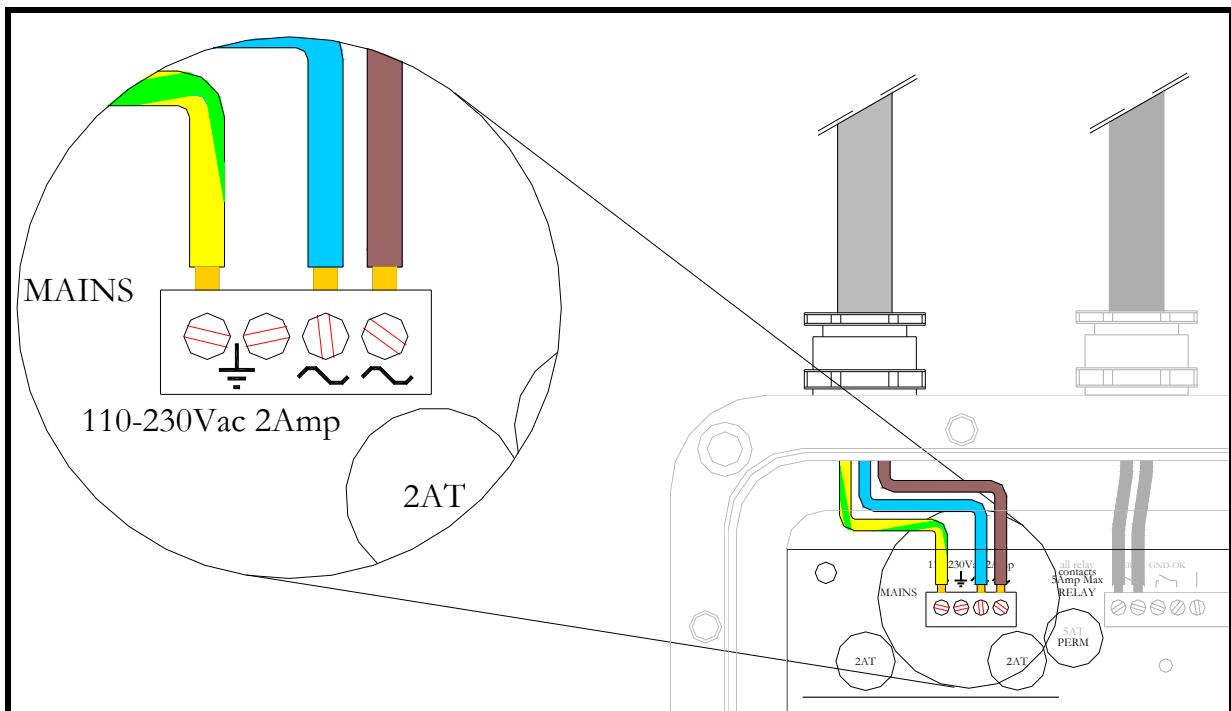

Figure 11

The mains terminal block is situated at the upper left corner of the metallic enclosure.

Since the 8800E/8801E rack monitor is equipped with a high efficient switching regulator with a wide operating range no settings has to made and all voltages between 110 and 230 Vac are accepted. The two left entries of the mains terminal is used to connect the earth wire and is internally connected to the chassis. The two right entries are the power terminals and the neutral conductor and the line conductor. Two internal (2AT) fuses are placed for mains current limitation.

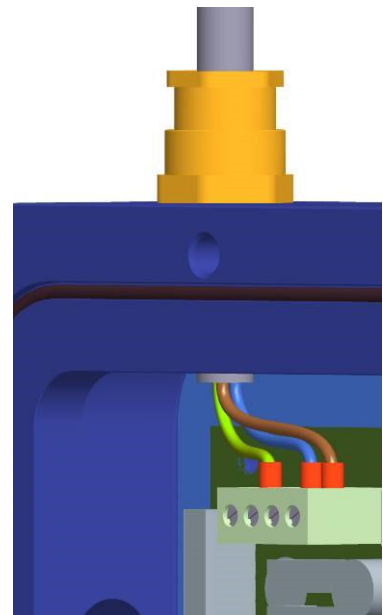

Figure 12

**Warning:** The electrical installation must be done according local regulations and code of practice.

## Relay outputs

Five relays are used to provide 4 relay outputs. All relays are voltage free relays and can be used within their specifications.

The permissive relay consists of two relays in series. When the rack monitor enters the permissive state the first relay K1 will switch to a closed position and after a short period the safety switch K2 will close the loop.

As soon as the rack monitor leaves the permissive state the safety switch K2 will switch to open first to break the loop and secondly the relay K1 will switch to open.

In this way K1 will always switch voltage- less. K2 is a special relay and monitored by the processor for failing or welded contacts. If K2 is stuck in one position K1 will open and stay open until K2 is repaired.

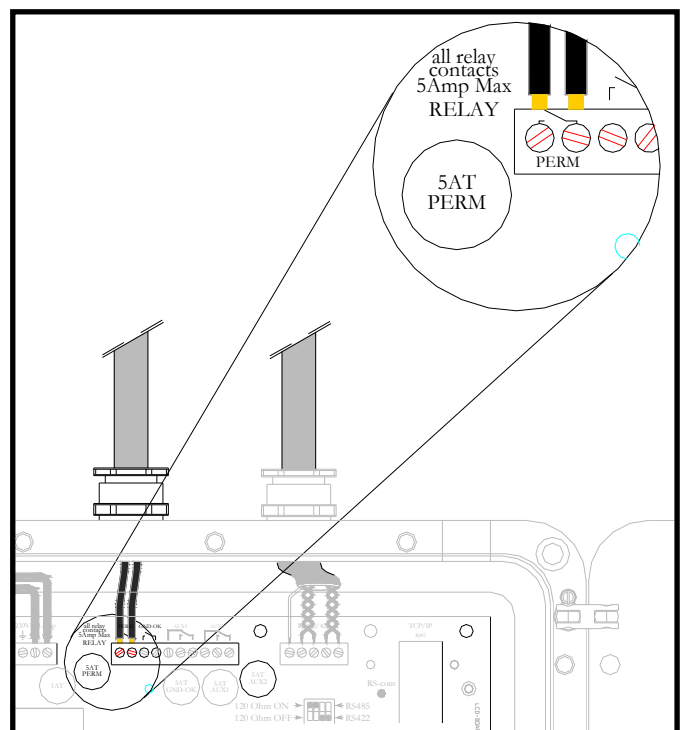
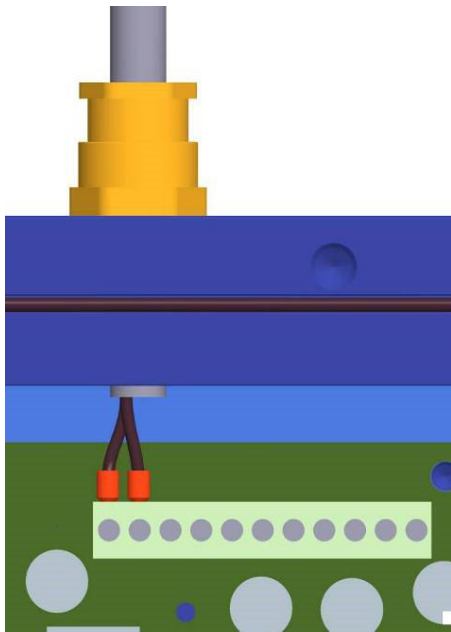

Figure 13



**Figure 14**

The two remaining Form C Auxiliary relays can be dedicated to other functionalities. E.g. The Aux relay can be used as a secondary Overfill permissive relay from software version 0.64 and higher. The white nr:9 dip switch needs to be up (on) to activate this functionality.

Ask OPW Fluid Transfer Group Europe BV for other available functionalities.

The second relay is closed when proper grounding of the truck is verified.

The permissive and ground verified relay are Form A normally open relays.

See Figure 13 and Figure 14 for details.  
All relay contacts are rated at 250 Vac, 5Amp resistive

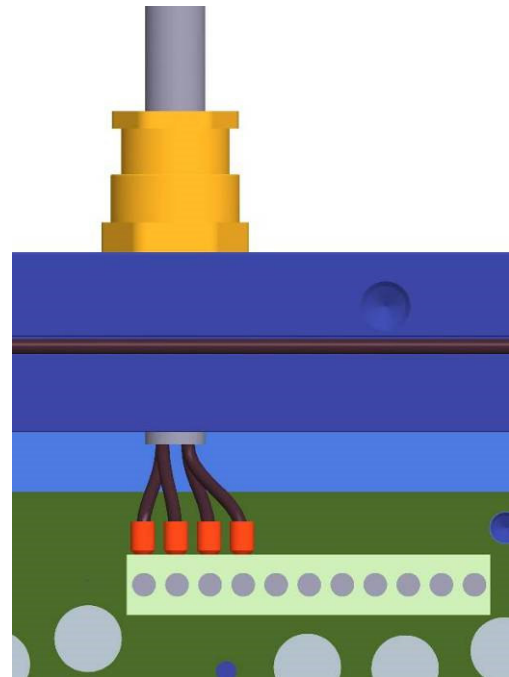

**Figure 15**

## Data communication

This Rack Monitor 8800E/8801E can be connected to the rest of the world by means of RS 485 half duplex or RS485 full duplex multi drop (See inside enclosure for detailed switch setting).

OPW Fluid Transfer Group Europe BV recommends 24AWG (7x32) tinned copper conductors, twisted pairs PVC insulated with laid up twisted pairs, lapped with an overall aluminum-polyester foil screen and 24AWG stranded tinned copper drain wire for each pair (e.g. Belden 9729 for RS422 and Belden 9841 for RS-485).

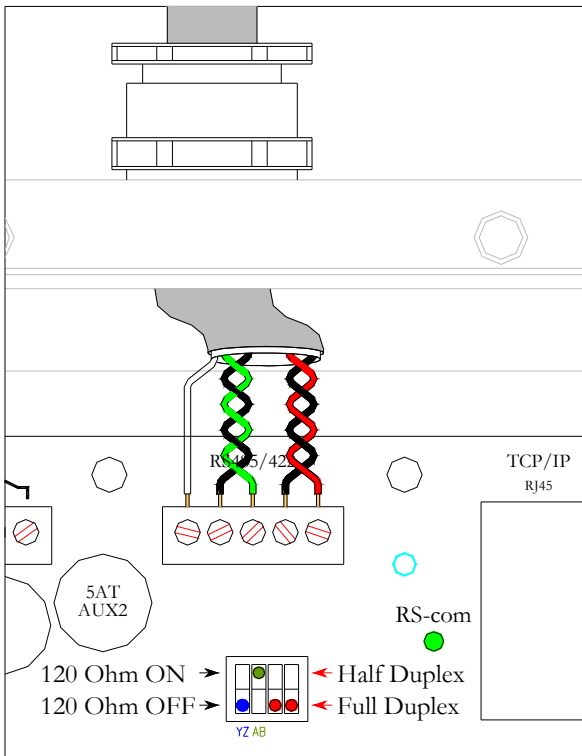

Figure 17

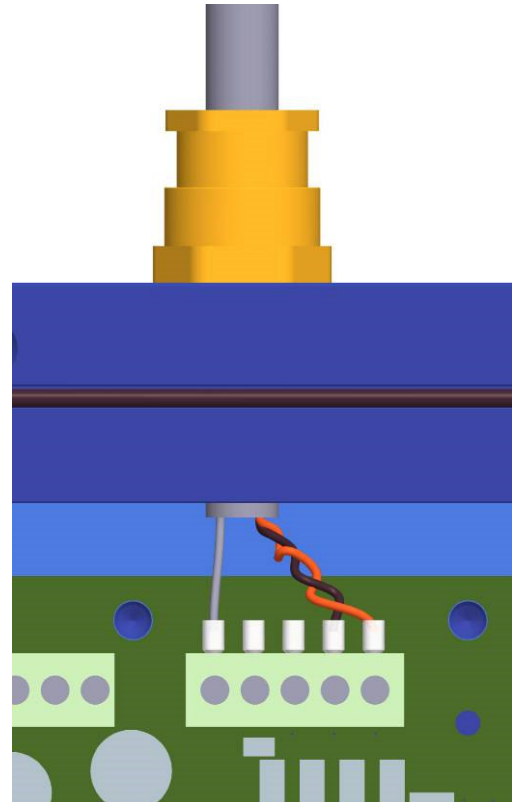

Figure 16

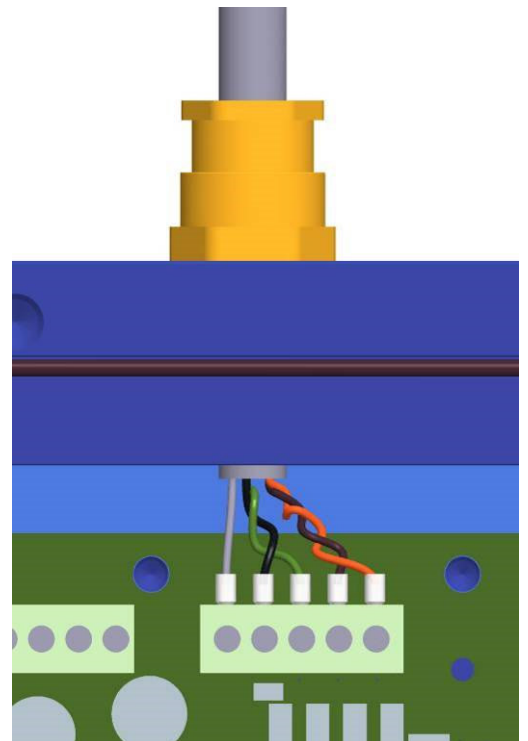

Figure 18

### Overall wiring top side

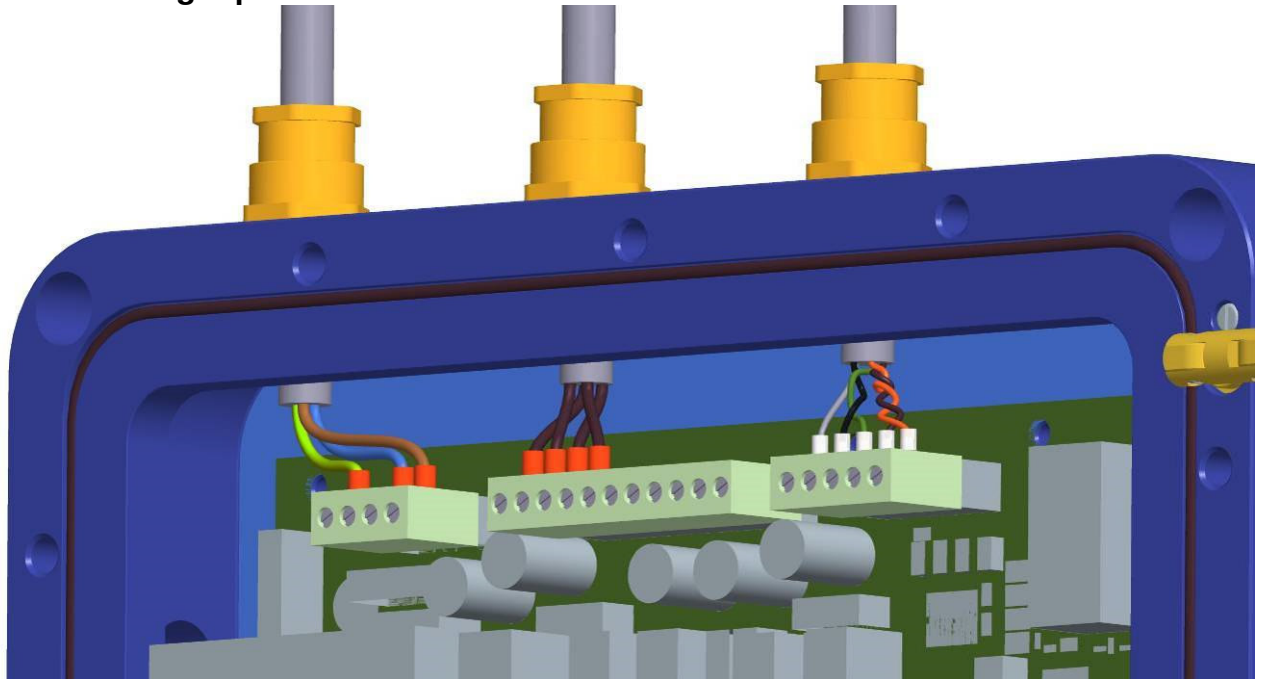

Figure 19

### Finishing installation

- Remove the corrosion protector from the seal and attach it to the door,

**Caution:** - Make sure, before closing the enclosure, that the cables do not get stuck between the door and the bottom side of the enclosure.

- Close the door, make sure to press the hinges completely into the enclosure,
- Connect all 12 bolts M8x25,

**Warning:** Do **not** leave any bolts out for a safe use.

- Tighten the bolts with a minimum of 14.5 Nm and a maximum torque of 27.6 Nm,
- Make sure that all earth cables are connected,
- Energize the system,

**Warning:** Do not make modifications to the Rack Monitor 8800E/8801E for alternative mounting (with exception of the mentioned method in Annex B - Modification Mounting Holes), when not making use of the initial mounting holes in the Rack Monitor 8800E/8801E any guarantees will be declined.

## 2 System configuration

A typical system consist of two parts.

- The Loading Rack Side
- The Tank Truck Side

The 8800E/8801E Rack monitor is mounted as a stationary system on a loading rack. Although the 8800E/8801E rack monitor is equipped with all basic functionality some extra parts can be added.

The minimum configuration (Figure 3.1) for a standard overfill prevention system for liquid fuels conform the NEN-EN13922 consist of

- A 8800E or 8801E Rack Monitor.
- A flexible 10 individually screened coiled cable.
- A black 10 pins 4J plug.

Contact OPW Fluid Transfer Group or local distributor for available optional system accessories.

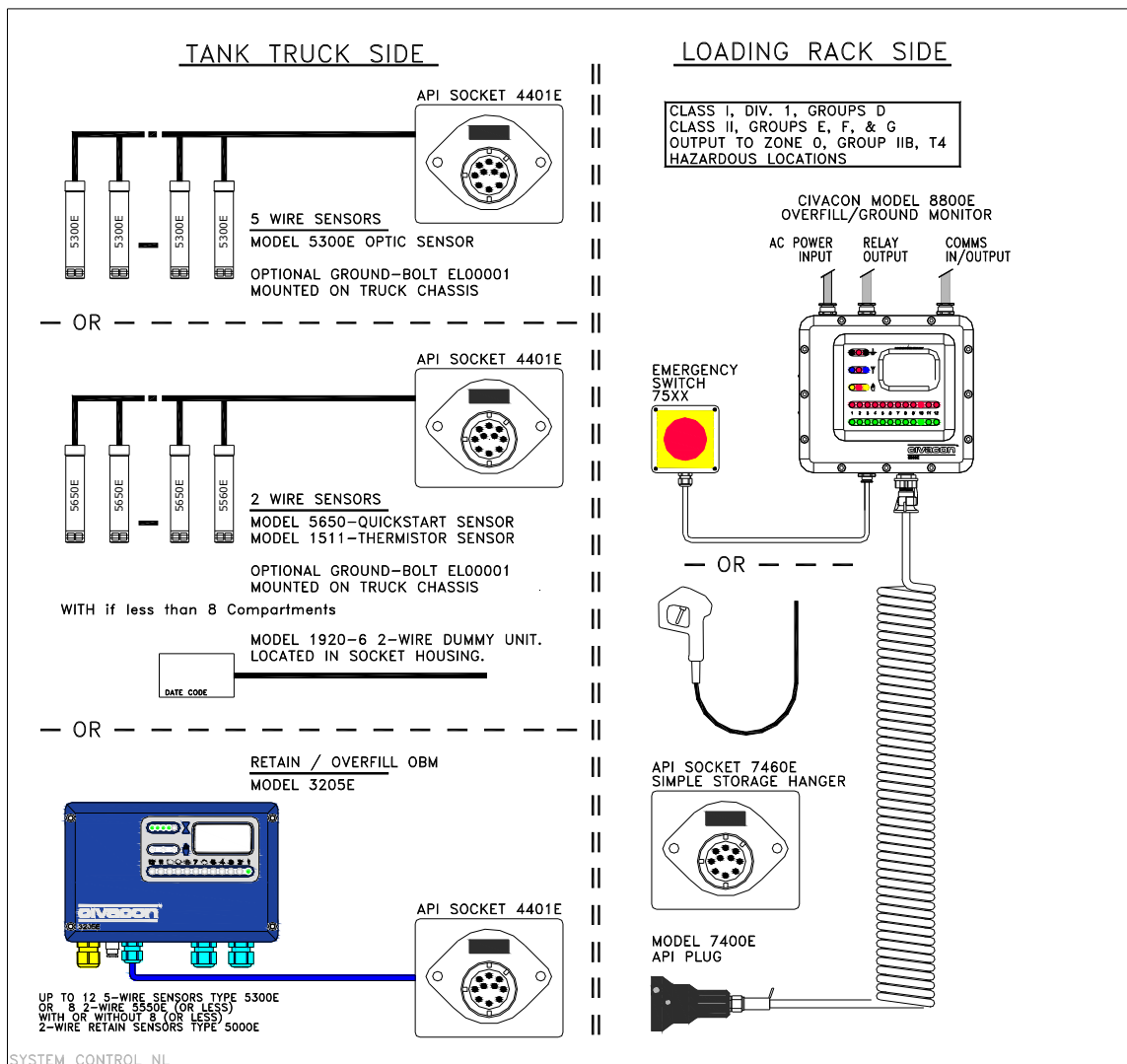

Figure 20

Another typical configuration is shown below.  
 Instead of flameproof cable glands Explosion proof seals are used.

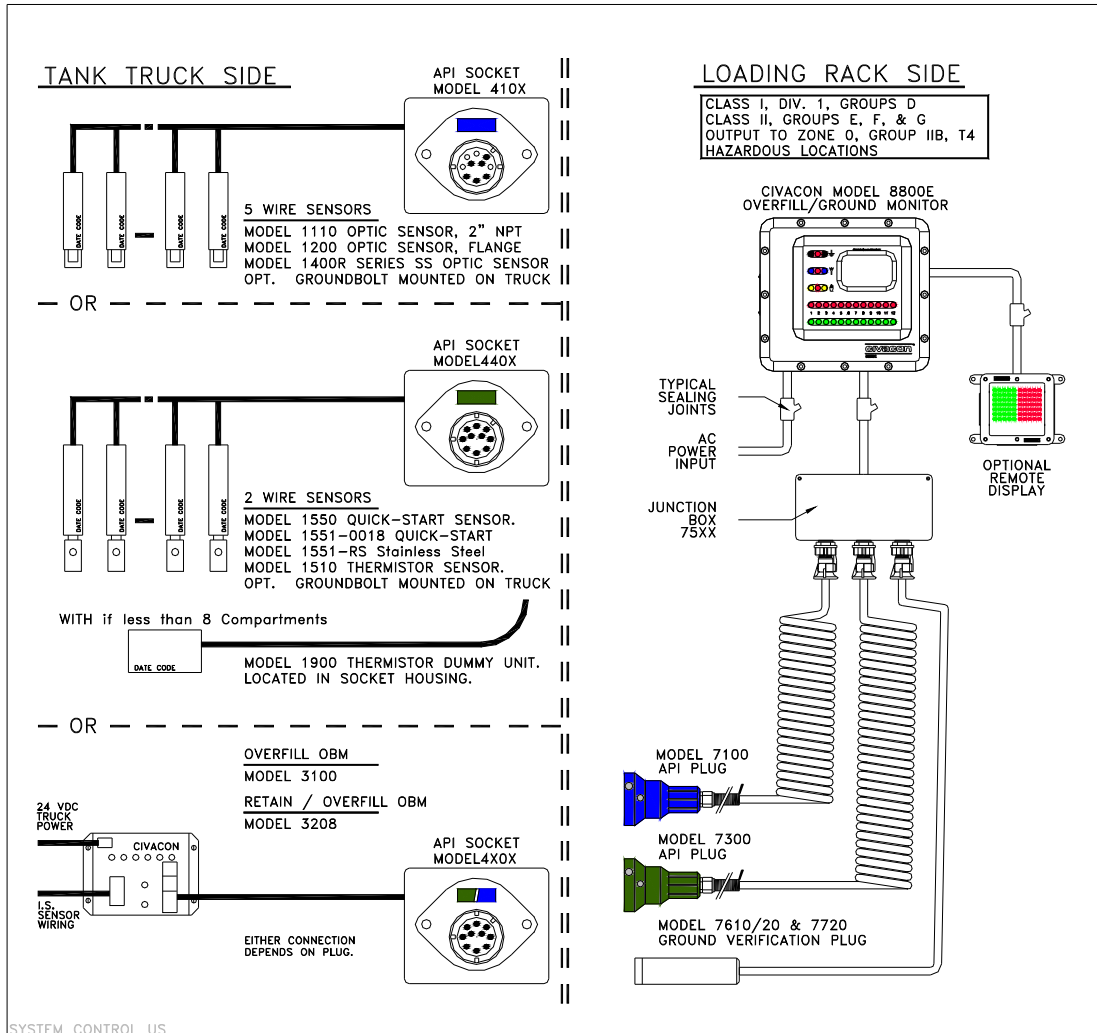

Figure 21

Read the installation manual of the explosion proof seals carefully to avoid dangerous situations.

Notes:

1. –Control Equipment and Electrical Apparatus connected to the 8800E / 8801E Rack monitor should NOT use or generate more than 250 Volts AC.
2. –Installation should be in accordance with Electrical installations in hazardous areas EN60079-14, EN50281 VDE-0165, NEC ANSI/NFPA 70 and ANSI/ISA RP12.6. In Canada, the system must be installed in accordance with the Canadian Electrical Code, CEC Part 1 and/or in accordance with all national and local regulations (codes) for installation of electrical equipment.
3. –Explosion-proof seals must be within xx inches of the enclosure.
4. –Only certified cable-glands (M20x1.5) for flameproof enclosure may be used.
5. –Only 4 seals may be used to connect the 8800E/8801E Rack Monitor.

Consult API Socket and Sensor drawings for detailed information.

## 3 Maintenance

Think of the following when servicing the Rack Monitor 8800E/8801E:

- Before maintenance the full installation must be shut down/off before proceeding,
- Maintenance must be performed by authorized personnel only,
- All fasteners must be inspected periodically,
- After maintenance is performed, the Rack Monitor 8800E/8801E must be tested before the next use,
- Periodical inspection (every 6 months) for leakages (especially with heavy rainfall or wind),
- Periodically maintenance is not required, but we recommend to check the internals at least once a year, by tucking all the cables and if there is no corrosion,
- Depending upon the condition of the inside the enclosure after inspection, it may be necessary to apply a coating of corrosion inhibiting spray to the interior components,
- Replace the corrosion inhibitor located on the inside of the door on a regular base. (part nr: H71307)
- During servicing loading and unloading of tank trucks is not allowed,
- During maintenance (partial) disassembling could be necessary, the same risks and procedures apply as during installation.
- Repairing of flame-paths is not allowed.

### 3.1 Check Points

During maintenance the following items should be checked:

- All earth cables should rigidly connected and free from corrosion,
- If there is no moisture inside of the enclosure,
- If the main seal is still intact and still soft and smooth,
- If there is no corrosion on any part inside the enclosure,
- Visual inspect all electronic components, with special attention for the voltage suppressors (also see chapter Trouble shooting)
- Check cable more periodically if the rack monitor is exposed to very cold weather conditions

When maintenance has been performed, the following should be done before closing the Rack Monitor 8800E/8801E:

- Replace the corrosion protector (should be done every 6 months),
- Put grease on the main seal,
- Make sure that all earth cables are connected,
- Apply coating (if necessary) to the interior components,

**Caution:** - Make sure, before closing the enclosure, that the cables do not get stuck between the door and the bottom side of the enclosure.  
- When tightening the bolts, apply the previously mentioned torque.

## 4 Operational Use

For a correct use of the Rack Monitor 8800E/8801E it is important to follow the instructions in the user Manual supplied to you together with the product and this installation manual.

The following applies:

- All incidents need to be reported to the **OPW Fluid Transfer Group Europe BV**. In case of injudicious use or when a calamity has occurred, the complete construction needs to be inspected according to the maintenance instructions.
- It is prohibited for unauthorized people to be in the near proximity of the Rack Monitor 8800E/8801E. Especially when the Rack Monitor 8800E/8801E is in use, only the operator is authorized to be in the working area of the Rack Monitor 8800E/8801E.



## 5 Dismantling Rack Monitor

**Attention:** Dismantling must be performed by authorized and trained personnel only.

At a certain moment (at the end of its lifetime) one could decide to stop using the Rack Monitor 8800E/8801E for monitoring the transfer of mediums. Also when one changes the infrastructure of the applicable area and the Rack Monitor 8800E/8801E must be moved to a new location, the Rack Monitor 8800E/8801E should be dismantled.

**Attention:** The same risks and procedures of initial installation apply.

**Warning:** Make sure what kind of environment this Rack Monitor 8800E/8801E is situated in. When the medium is nuclear, hazardous or toxic, one is obligated to clean the parts with the help of specialized personnel, companies or governments.

Before dismantling the Rack Monitor 8800E/8801E take some necessary preparations.

- Use the box which came with the initial purchase or when it is not present (anymore) use a suitable box to transport the Rack Monitor 8800E/8801E.

Or

- Arrange a container or boxes where disassembled parts can be placed in,
- **Make sure to use adequate personal protection at all time during the operation,**
- Arrange necessary permits or paperwork with the plant holder, owners or local authorities, before taking any actions,

When the Rack Monitor 8800E/8801E is clean and dry and the necessary preparations are made, the Rack Monitor 8800E/8801E can be disassembled from its position.

- Dismount the bolts from the door of the Rack Monitor 8800E/8801E,
- Open de door by 180° (see Figure 3),
- Disconnect all cables,
- Dismount the bolts from the connecting plate between the Rack Monitor 8800E/8801E and the Stand Post,
- Take down the Rack Monitor 8800E/8801E.

**Warning:** When removing the last bolt, make sure that it doesn't fall onto the ground, if necessary put straps around and use a hoisting device to lift the Rack Monitor 8800E/8801E.

- Secure the parts from moving, by securing them with the bolts from the door (use at least 2 bolts and send the remaining back separately),

Or

- Take the Rack Monitor 8800E/8801E apart by disconnecting all the connection parts,
- Remove all the parts,
- Dispose the parts separately, so the parts can be recycled,

Or

- Send the Rack Monitor 8800E/8801E back to **OPW Fluid Transfer Group Europe BV**

Take into consideration the risk disassembling the Rack Monitor 8800E/8801E could form. When one is unspecialized in this kind of dismantling operations, gain information with the local reseller/companies, the local governments or the **OPW Fluid Transfer Group Europe BV**.

## 6 Trouble shooting

Although Many events are displayed on the screen a there are always problems that cannot be measured automatically. Read operation manual for operational related problems.  
On all relay contacts and at the power inlet voltage terminal suppressors are placed to limit the surge voltage and current as well as for absorbing energy. These Surge protecting devices protects the Rack input voltage and relay contacts against surges generated by electromagnetic effects, such as lightning or electrostatic discharge, over-voltages and high inductive loads. If such a device is overloaded it can explode during the protection process. Consult OPW if this has happened.  
Do **NOT** replace fuses if the reason of a blown fuse is unknown.

**Caution** : When replacing the fuses, always make sure that you replace the fuse with original ones with an equal stated value.

## 7 Procedure in case of an Error or Emergencies

Many events could happen when working or installing a Rack Monitor 8800E/8801E. Therefore a summary is made of a few events and errors and the possible solutions.

Important is when personal infliction has occurred the local medical services are contacted immediately, the **OPW Fluid Transfer Group Europe BV** cannot being held responsible for none, late or erroneous medical care.

When there is no personal infliction, but there is a high risk of explosions, fire or environmental disorders the local authorities should and must be contacted before contacting the **OPW Fluid Transfer Group Europe BV**.

Condition	Possible Cause	Solution
- Not all bolts can be applied to mount the enclosure to its designated position.	- Check whether the drill pattern is right.	- Correct the hole pattern - Check if the bolts are M8x65
- The Rack Monitor 8800E/8801E doesn't turn ON	- The mains connector isn't connected.	- Connect the mains connector.
		- Check if the main wiring is connected according to the installation instruction.
		- Check if there is any power available at the terminal of the Rack Monitor 8800E/8801E.
	- The fuses are broken.	- Replace the fuses for new ones.
- The door cannot being closed	- The hinges aren't completely straight in the enclosure.	- Open the door again, lift it and try to put the hinges in straight.
	- There is a cable between the door and the back of the enclosure.	- Remove the cable (bend it the other way) and try to close the door again.
- System goes directly into 'NON PERMISSIVE'	- The deadman switch is not connected.	- Connect the cable according to the installation manual. - Connect a bypass cable between pin 1 & 2 according to the installation manual.

For all other possible inflictions/damages to the Rack Monitor 8800E/8801E, contact **OPW Fluid Transfer Group Europe BV** and ask for assistance to obtain a safe and right use.

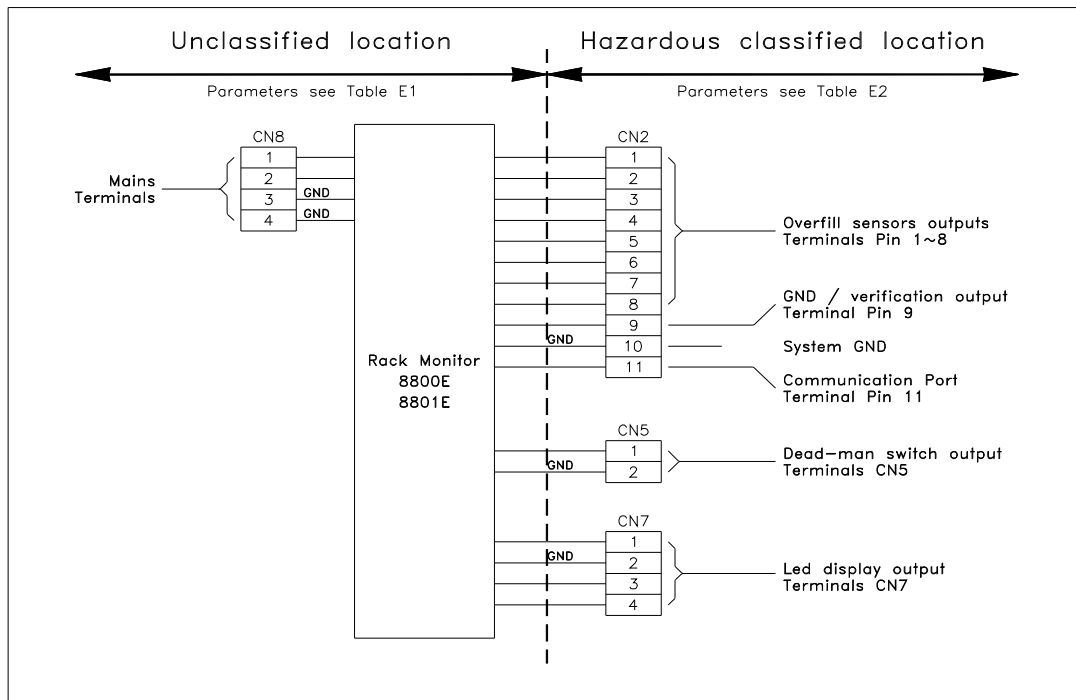

Figure 22

Parameters	Terminal CN8
$U_i$	230Vac
$I_i$	200mA
$P_i$	30W
$C_i$	Negligibly small
$L_i$	Negligibly small

Table 2

Terminals						
Entity	2 Wire	5 Wire	Grounding	Data	Emergency Sw	Internal
Parameters	CN2 / pin1~8	CN2 / pin 4,5,6,8	CN2 / pin9	CN2 / pin11	CN5	CN7
$U_o$	12,6 V	12,6 V	12,6 V	12,6 V	12,6 V	12,6 V
$I_o$	200mA	800mA	56mA	121mA	28mA	45mA
$P_o$	630mW	2,52 W	178mW	380mW	89mW	1,41W
$C_o$	3,7 $\mu$ F	3,7 $\mu$ F	3,7 $\mu$ F	3,7 $\mu$ F	3,7 $\mu$ F	3,7 $\mu$ F
$L_o$	2mH	110 $\mu$ H	22,5mH	4,5mH	90mH	32,5mH

Table 3

**Sensor cable specifications:**

**OPW** recommends to use our high quality individually screened blue cable part number 7400E.

If another equivalent cable is used the inductance  $L_i$  must be less or equal to 0,8 mH / km for a maximum length of 40 meters. In case of using cable with a higher inductance the cable length must be reduced accordingly.

## Annex A - Available detail wiring drawings of the Rack Monitor 8800E/8801E and associated parts

- Drawing(s)

DS00257	RS-485 WIRING DIAGRAM
DS00258	BLACK PLUG WIRING
DS00259	7511E DUAL BREAK AWAY

## Annex B - Modification Mounting Holes

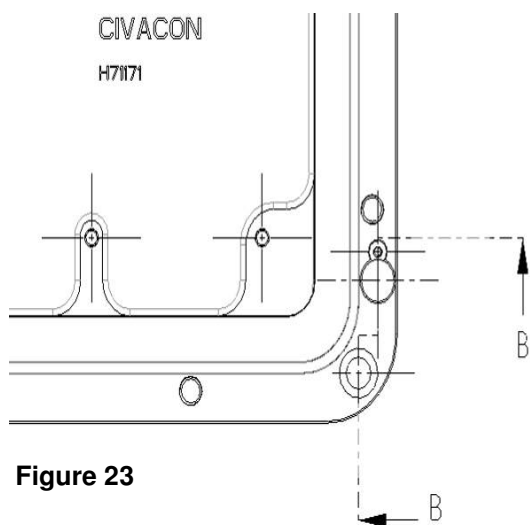

Figure 23

Make sure that the M10 bolt used to mount the Rack Monitor 8800E/8801E from the rear is mounted into to hole at least 1.5 times the diameter of the M10 bolt.

The Rack Monitor 8800E/8801E is equipped with 4 mounting holes. The Bolts, Washers and Nuts are supplied to you with the purchase of this product. If it is not possible to apply this bolts and nuts, the bottom side of the enclosure may be modified.

The bottom side of the enclosure can be modified by applying screw thread to the existing mounting holes (Figure 26 section B-B). The mounting hole can be adjusted to M10 and a depth of approximately 20mm. This can be applied to all 4 mounting holes.

Warning: Do NOT change the mounting holes in any other way then mentioned before and as can be seen in de corresponding figures on this page or else all guarantees will be declined.

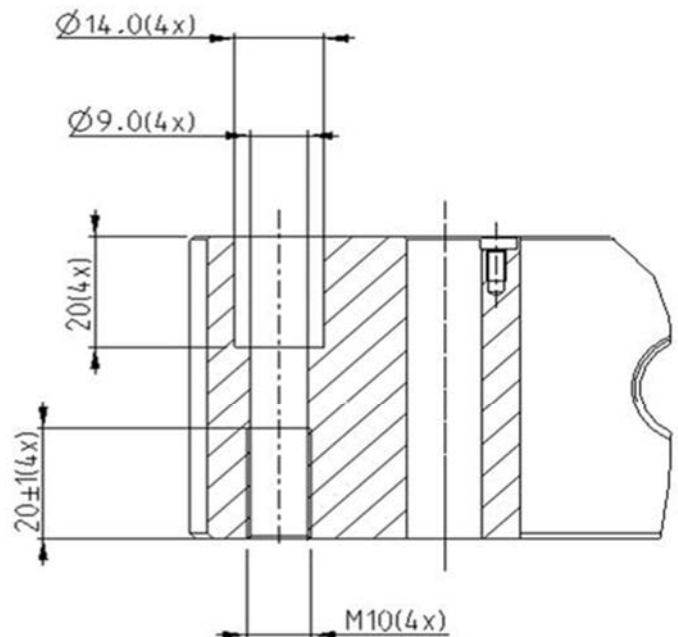

Figure 24

SECTION **B-B**  
SCALE 1:1

## Annex C - Recommended Spare Parts

With the purchase of the Rack Monitor the **OPW Fluid Transfer Group Europe BV** recommends some spare parts to be purchased. Although this Rack Monitor 8800E/8801E is designed with solid state lamps and minimum maintenance components, spare parts are available. When parts are replaced, it is recommended to replace them with the original parts.

The recommended spare parts are:

Part number	Description	Quantity
H71197	Main Seal	1
H71307	Corrosion Protector VCI-101/ACF-50	1
EL04141	Mains power input Fuse 2AT	1
EL04142	Relay contact output Fuses 5AT	1

The following parts are also available:

Part number	Description	Quantity
EL04139	Liquid Crystal Display cable assembly	1
EL00203-CRK	Internally used connector kit	1
BCU-BLUE	Blue Function key (low level)	1
BCU-RED	Red Function key (high level)	1
8800-BRK	Fastener kit 12x Door Bolts	1
H71343	Operation manual	1
EL05104	Cable gland M20x1,5 Ø cable diameter 10-14mm ATEX-Ex/d (not armed)	1
EL05134	Cable gland M20x1,5 Ø cable diameter 3.1-8.6mm ATEX-Ex/d (not armed)	1
7400E	Black Plug and 10-conductor individual screened coiled cable.	1

see insert for  
**Quality Certificate, Functional Inspection, EC Declaration of Conformity**

### Rack Monitor Test equipment.

An Automatic Rack Tester 1386E can be used to test the rack monitor and cable. Ask OPW for availability.